

# Fast light in silicon ring resonator with resonance-splitting

Qiang Li,<sup>1</sup> Ziyang Zhang,<sup>2</sup> Jing Wang,<sup>2</sup> Min Qiu,<sup>2</sup> and Yikai Su<sup>1,\*</sup>

<sup>1</sup>State Key Lab of Advanced Optical Communication Systems and Networks, Department of Electronic Engineering, Shanghai Jiao Tong University, 800 Dongchuan Rd, Shanghai 200240, China

<sup>2</sup>Department of Microelectronics and Applied Physics, Royal Institute of Technology, Electrum 229, 164 40 Kista, Sweden

\*Corresponding author: [yikaisu@sjtu.edu.cn](mailto:yikaisu@sjtu.edu.cn)

**Abstract:**

μ

©

---

## References and links

17  
18  
406  
86  
425  
13  
13  
73  
312  
32  
301  
88  
15  
14  
406  
86  
312

23

73

427

1

1

16

49

16

15

35

51

15

14

---

## 1. Introduction

fi fi  
fi

$\mu$

## 2. Operational principle

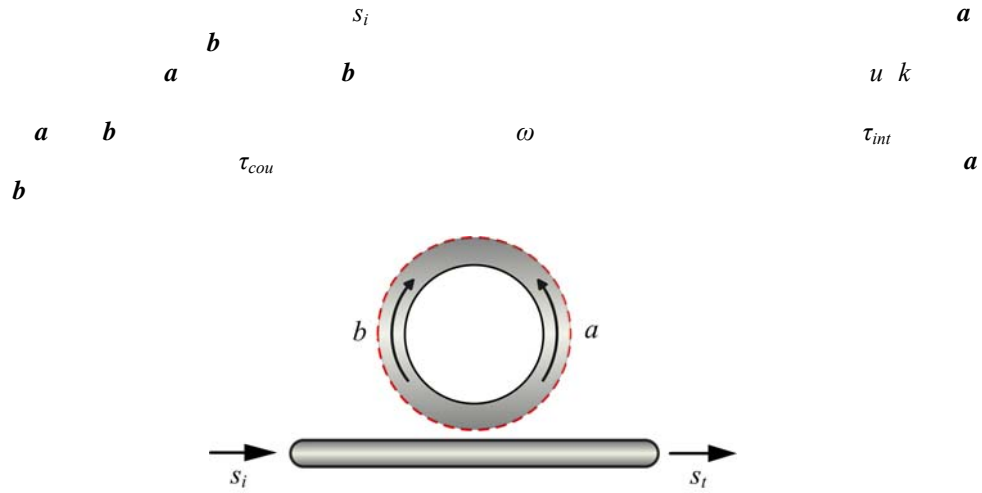

$$\frac{d}{dt}a = \left( j\omega - \frac{\tau_{int}}{\tau_{cou}} \right) a - jks_i - jub$$

$$\frac{d}{dt}b = \left( j\omega - \frac{\tau_{int}}{\tau_{cou}} \right) b - jua$$

$$Q_{int} \omega \tau_{int} \omega \alpha v \omega k^2$$

$$Q_{cou} \omega \tau_{cou} \omega k^2$$

$$v$$

$$s_i \quad Q_{mut} \omega \quad u$$

$$s_t \quad s_t = s_i \quad jka$$

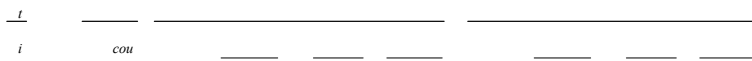

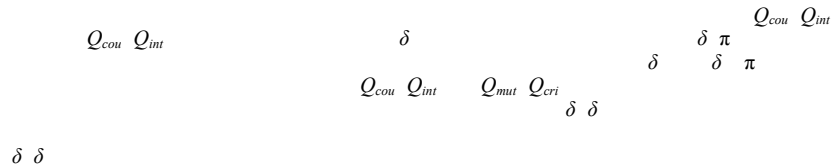
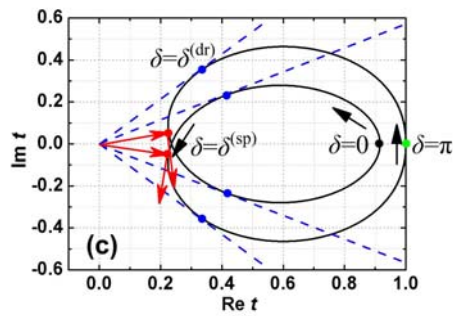
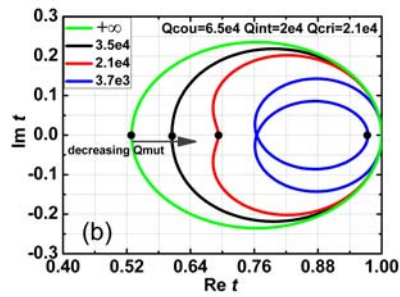
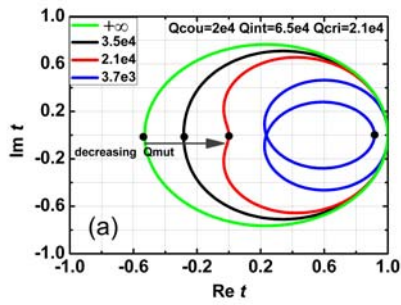
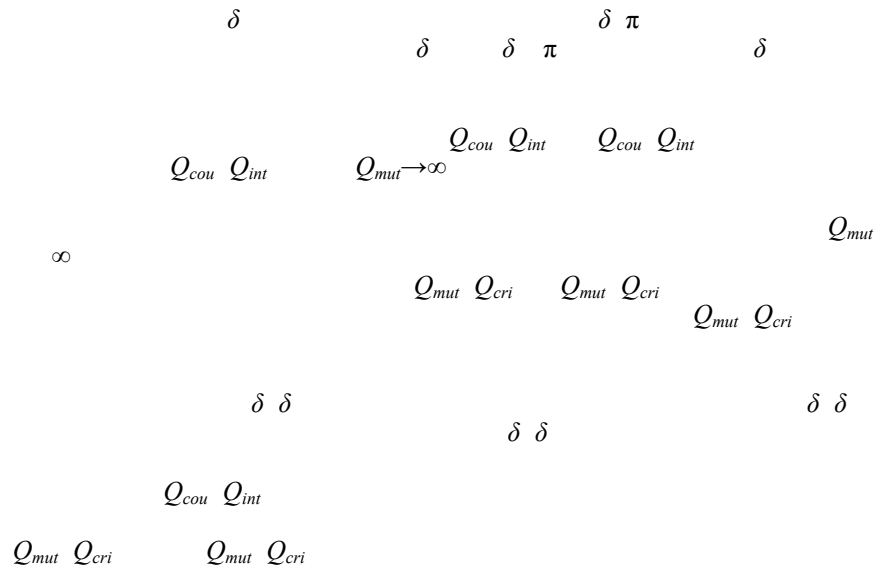

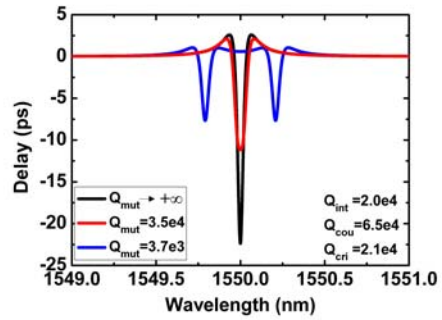
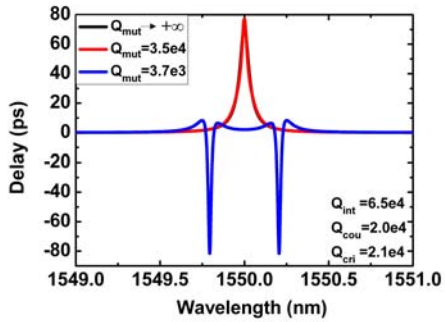
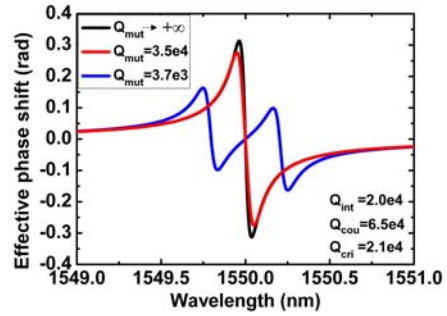
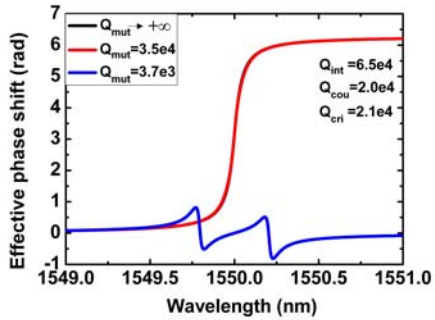
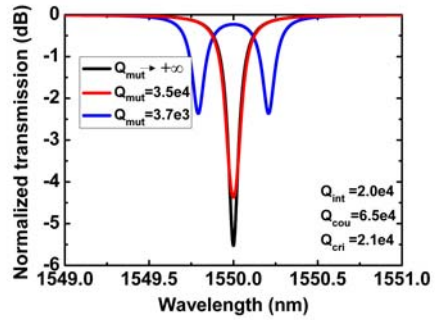
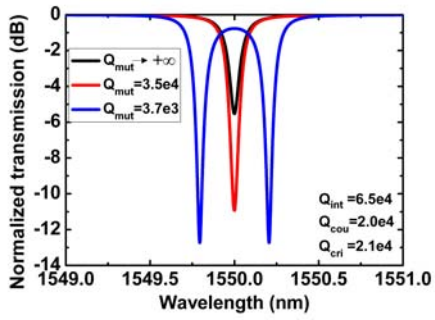

$Q_{cou} \quad Q_{int}$

$Q_{cou} \quad Q_{int}$

$Q_{cou} \quad Q_{int}$	$Q_{mut} \quad Q_{cri}$		
	$Q_{mut} \quad Q_{cri}$		
$Q_{cou} \quad Q_{int}$	$Q_{mut} \quad Q_{cri}$		
	$Q_{mut} \quad Q_{cri}$		

$Q_{mut} = Q_{cri}$

### 3. Device characterization

$\mu$   
 $\mu$

$\mu$

$\mu$

$Q_{mut}$

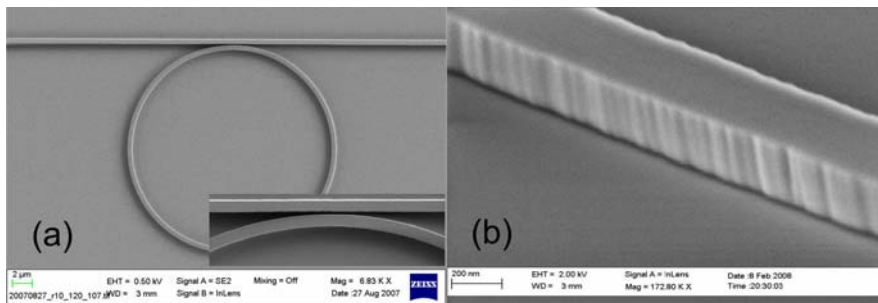

$\mu$

$Q_{mut}$

$\mu$

$Q_{cou}$

$Q_{int}$   
 $\mu$

$\mu$

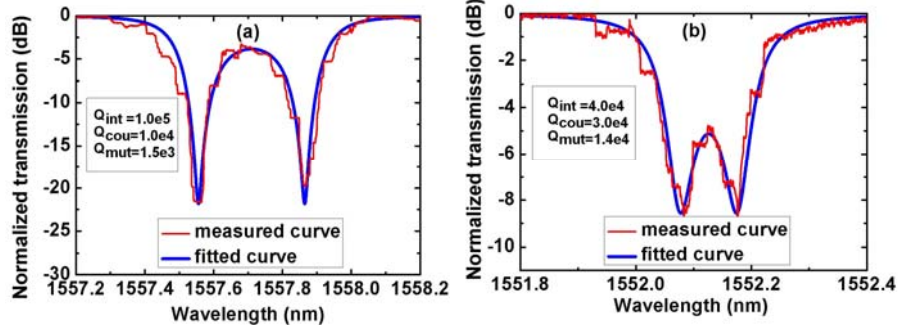

μ

μ

#### 4. Experiments and results

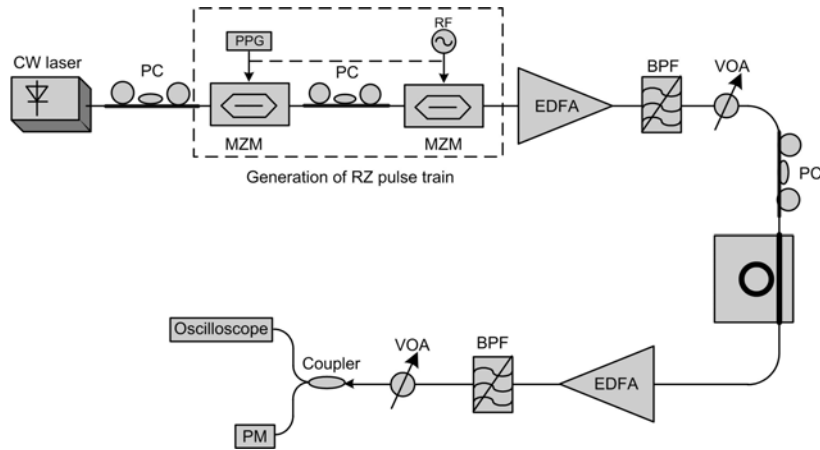

μ

μ

μ

μ

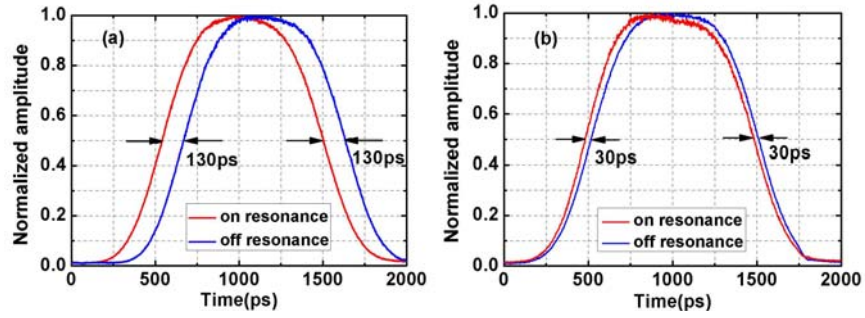

μ

μ

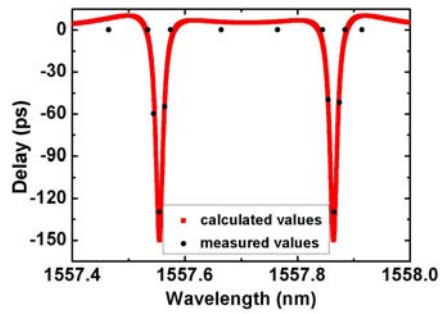

μ

## 5. Conclusions

μ  
 $Q_{cou}$   $Q_{int}$

μ  
μ

μ

## Acknowledgments