

A PON System Providing Triple Play Service Based on a Single Dual-Parallel Mach-Zehnder Modulator

Qingjiang Chang, Yue Tian, Cishuo Yan, Xinyu Xu, Junming Gao and Yikai Su
State Key Lab of Advanced Optical Communication Systems and Networks, Department of Electronic Engineering, Shanghai Jiao Tong University, Shanghai, 200240, China. Email: yikaisu@sjtu.edu.cn

Abstract We propose and experimentally demonstrate a novel PON system providing triple play service with centralized light source using a single dual-parallel Mach-Zehnder modulator. Upstream data re-modulation based on downstream DPSK format is also achieved.

Introduction

The convergence of video, voice and data into triple play service (TPS) in a single network is an attractive solution for network service providers [1]. However, this also presents a great challenge in the demand of capacity and security for services delivery and real-time applications. Passive optical network (PON) technology is believed to be a promising scheme to provide TPS in an integrated platform with a cost-effective configuration [2, 3]. In previous demonstrations, however, only video, downstream data and upstream data were transmitted, simultaneous delivery of TPS including video, voice and data in the downstream were not demonstrated.

In this paper, we propose and experimentally demonstrate a novel PON system to deliver video, voice and data using a single dual-parallel Mach-Zehnder modulator (DPMZM). To the best of our knowledge, our scheme realizes the centralized modulation of TPS signals with a single wavelength for the first time. Upstream data re-modulation based on downstream DPSK format is also achieved. Compared to [3], our scheme does not require a light source in the optical network unit (ONU) for upstream signal modulation. While compared to the transmitter in [4] which uses a number of discrete optical components, our single integrated transmitter shows low insertion loss and reduced size.

Principle

The DPMZM [4] consists of a pair of x-cut LiNbO₃ MZMs (MZMA, MZMB) embedded in the two arms of a main MZM structure. The two sub-MZMs have the same architecture and performance, and the main MZM combines the outputs of the two sub-MZMs. The DPMZM was initially designed for the generation of single side-band (SSB) signal. In this paper, we demonstrate that this modulator can be used as a transmitter for delivery of TPS in PON systems.

The schematic diagram of the proposed PON system is depicted in Fig.1. At the optical line terminal (OLT), the output of a continuous wave (CW) laser is launched into the DPMZM. The MZMA is biased at its null point and driven by a RF signal loaded with video signal to generate a carrier suppressed optical sub-carrier multiplexing (SCM) signal. The MZMB is also biased at its null point and driven by data to obtain a

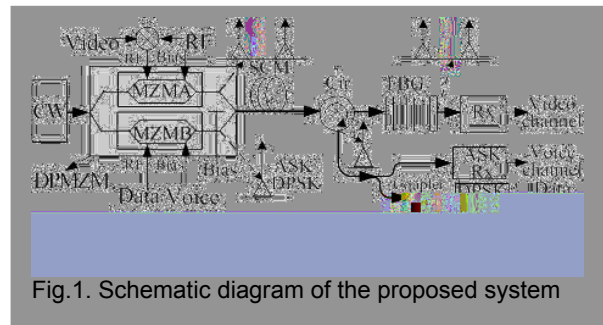

Fig.1. Schematic diagram of the proposed system

DPSK signal. The voice signal is superimposed onto the DPSK signal to form ASK/DPSK format by modulating the bias point of the MZMB between the null point and a small fraction of switching voltage [5]. The output of the MZMA and the MZMB are then added constructively by adjusting the bias of the main MZM, and they do not interfere with each other, since the carrier of the optical SCM signal is suppressed. In this manner, the triple play signals are carried in the SCM, the ASK/DPSK formats, respectively.

After the transmission, at the ONU, a fiber Bragg grating (FBG) with an optical circulator is used to reflect the ASK/DPSK signals while pass through the optical SCM signal. The passing optical SCM signal is directly detected by a low-speed optical receiver to retrieve the video signal. The reflected ASK signal is detected by an optical receiver to recover the voice signal, and the reflected DPSK signal is split into two parts, one is detected by a DPSK receiver to retrieve the data signal, and the other part is re-modulated by the upstream signal to the OLT. Therefore, simultaneous delivery of TPS and re-modulation for upstream signal are realized in a simple and compact manner.

Experimental setup and results

Fig. 2 shows the experimental setup for providing TPS in PON networks. A 10-GHz DPMZM (COVEGA Mach-10060) is used to modulate a CW light from a tunable laser at 1549.88 nm. The electrical SCM signal is obtained by mixing a 1.25-Gb/s pseudorandom bit sequence (PRBS) data1 of 2^7-1 with a 10-GHz RF signal, the waveform is inserted in Fig.2 as inset (i). The sub-MZMA is biased at the null point and driven by the mixed signal to generate optical SCM signal of 20-GHz rate, the eye diagram, the waveform and the spectrum are shown in insets

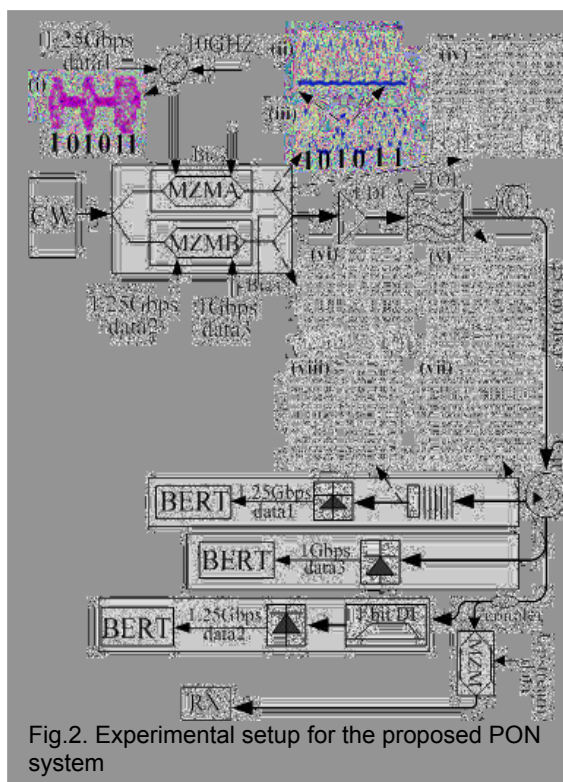

(ii), (iii) and (iv) of Fig.2, respectively. The downstream ASK/DPSK signals are obtained by driving the sub-MZMB using another PRBS data2 at 1.25 Gb/s, and a data3 at 1 Gb/s, both with a word length of 2^7-1 . The generated optical spectrum is provided in inset (v) of Fig.2. In this particular experiment, simultaneous ASK and DPSK modulations are not demonstrated due to the lack of a high-power modulator driver for providing an output swing of $2V_{\pi}$. Instead, the ASK and the DPSK are transmitted separately in interleaved time slots, thus in this case scheduling is needed to avoid contention between the ASK and DPSK traffic [5]. The outputs from the MZMA and the MZMB are constructively added and amplified by an erbium-doped fiber amplifier (EDFA) to 6.5 dBm for transmission. A tunable optical filter (TOF) with a bandwidth of 0.4 nm is used to suppress amplified spontaneous emission (ASE) noise and the amplified optical signal spectrum is shown in inset (vi) of Fig.2.

After transmission over 25-km standard single-mode fiber (SMF), an FBG with a 3-dB bandwidth of 0.1 nm and a reflection ratio of 90% is used to separate the ASK/DPSK signals and the optical SCM signal, the spectra of the reflected signal and the passing signal are inserted in Fig.2 as insets (vii) and (viii), respectively. The passing optical SCM signal loaded with data1 is converted into the electrical signal by using a 2.5-GHz PIN to directly detect the optical SCM signal. For the reflected ASK/DPSK signals, the ASK signal is detected using a 2.5-GHz PIN, and the DPSK signal is split into two parts, one part is converted into the intensity signal by employing a 1-bit

delay interferometer and is then detected by a 2.5-GHz PIN. The other part is re-modulated by a 1.25-Gb/s upstream data4 with a word length of 2^7-1 to generate an on-off keying (OOK) signal. The upstream OOK signal is sent back to the OLT and detected using a 2.5-GHz PIN.

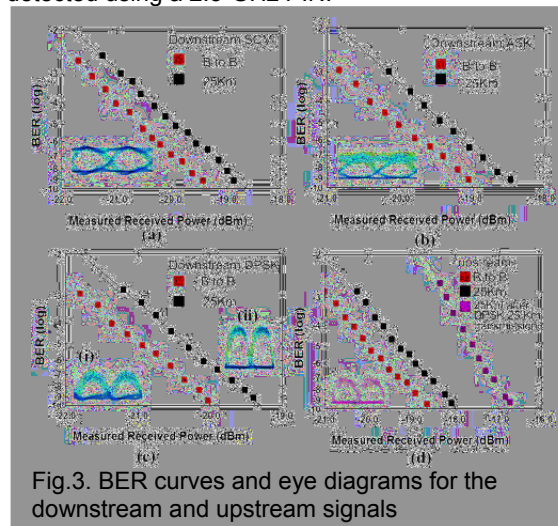

Fig.3 shows the BER curves and the eye diagrams for the downstream and upstream signals. For the downstream SCM signal and the ASK/DPSK signals, after transmission of 25 km, the power penalty is smaller than 0.8 dB. The electrical eye diagrams are shown in insets of Fig.3 (a), Fig.3 (b) and inset (i) of Fig.3 (c), respectively, and the optical eye diagram for the downstream DPSK after the interferometer is inserted in Fig.3 (c) as inset (ii). For the re-modulated upstream OOK signal, the power penalty is about 1.3 dB after 25-km transmission of DPSK downstream signal at OLT, and the electrical eye diagram is provided in inset of Fig.3 (d).

Conclusions

We have proposed a novel PON system for providing TPS and experimentally demonstrated the simultaneous delivery of the three downstream signals of different data patterns, using a single integrated DPMZM. We also demonstrated upstream data re-modulation based on downstream DPSK format.

Acknowledgement

This work was supported by the NSFC (60407008), the 863 High-Tech program (2006AA01Z255), the key project of Ministry of Education (106071), and the Fok Ying Dong Fund (101067).

References

- 1 Soo-Jin Park et al., JLT Vol. 22 (2004), 2582.
- 2 J. Yu et al., OFC 2007, OWS4.
3. M. Khanal et al., PTL, Vol. 17(2005), 1992.
- 4 K. Higuma et al., Electron. Lett., vol. 37(2001), 515.
- 5 Yue Tian et al., ECOC 2006, Tu4.5.6.